

NPI and NPD field of view obstructions on Mars and Venus Express

Shahab Fatemi

IRF Technical Report 050
May 2009

ISSN 0284-1738

INSTITUTET FÖR RYMDFYSIK

Swedish Institute of Space Physics

Kiruna, Sweden

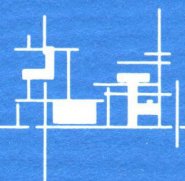

NPI and NPD field of view obstructions on Mars and Venus Express

Shahab Fatemi
Swedish Institute of Space Physics
Kiruna, Sweden
May 2009

S. Shahab Fatemi Moghareh
IRF Technical Report 050
ISSN: 0284-1738
Swedish Institute of Space Physics
P.O. Box 812
SE-981 28 Kiruna
SWEDEN
shahab@irf.se

Printed in Sweden by Swedish Institute of Space Physics, Kiruna 2009.

Acknowledgments

I have to thank my supervisor Associate Prof. Mats Holmström who has given me the best of support and guidance and shared with me his knowledge and experience on the subject of this study and given me the chance of doing this work.

I would like to thank all Swedish Institute of Space Physics (IRF) staffs in Kiruna, especially Prof. Stas Barabash, Dr. Futaana Yoshifumi and Mr. Magnus Oja who have helped me to finish this report.

Abstract

ASPERA-3 and ASPERA-4 are two instruments which have been built by the Swedish Institute of Space Physics in Kiruna - Sweden, mounted on Mars Express and Venus Express ESA mission satellites. They are made up of two main components: the Ion Mass Analyzer (IMA) and the Main Unit (MU). ASPERA-MU is comprised of 3 sensors: NPI, NPD and ELS.

The purpose of this report is to study NPI and NPD field of view obstructions to find when their sectors are blocked by different parts of the satellites. A software was developed in MATLAB to calculate and show the NPI and NPD blocked sectors and the final results are saved in a text format file.

Contents

1. Introduction	7
2. ASPERA	7
3. Geometry	9
3.1. Coordinate system and reference frames	9
3.2. Satellite Body	11
3.3. High Gain Antenna (HGA)	12
3.4. Solar Arrays (SA)	13
3.5. ASPERA-MU	14
3.6. NPI	20
3.7. NPDs	22
4. Algorithm and outputs	25
5. Software structure	27
5.1. Public functions	27
5.2. Setting functions	28
5.3. Calculation routines	28
5.4. Output functions	28
6. Results	29
7. Summary	35
8. Future work	36
Appendix-A	37
Appendix-B	38
Appendix-C	39
Appendix-D	41
References	45

List of Figures

Figure 1. ASPERA-MU and its components	8
Figure 2A. X side view of MEX reference frame	9
Figure 2B. Z side view of MEX reference frame	9
Figure 3A. X side view of VEX reference frame	10
Figure 3B. Z side view of VEX reference frame	10
Figure 4. MEX ASPERA-MU reference frame	10
Figure 5. VEX ASPERA-MU reference frame	11
Figure 6. Definition of the coordinate system used in this paper with default setting	12
Figure 7. Definition of the H.G. Antenna Disc	13
Figure 8. H.G. Antenna seen from -Y (left) and from +X (right) axes	13
Figure 9. Solar Panels definition on VEX	14
Figure 10. Solar panel rotation angle definition for both MEX and VEX	15
Figure 11. Mounting position of ASPERA-MU for MEX	16
Figure 12. ASPERA-MU location on MEX seen from +X (upper) and -Y (lower) axes	16
Figure 13. Definition of MEX ASPERA-MU rotation angle	17
Figure 14. Definition of ASPERA MU rotation angle on MEX in the unit frame	17
Figure 15. Relation between ASPERA MU rotation angle and the coordinate system	18
Figure 16. Mounting position of ASPERA-MU for VEX	18
Figure 17. ASPERA-MU location on VEX	19
Figure 18. Relation between ASPERA MU rotation angle...	19
Figure 19. NPI outer and inner aperture	20
Figure 20. Definition of FOVs of NPI for MEX and VEX and their numbering	20
Figure 21. Sample points for each NPI sector	21
Figure 22. Parameters used to define the FOV for NPI	21
Figure 23. NPD FOV and its focal point	22
Figure 24. Definition of NPD sensor numbering	22
Figure 25. NPD tilted angles	23
Figure 26. NPD sample points	23
Figure 27. Definition of NPD sample points order and their distances in one NPD sector	23
Figure 28. NPD sample points	24
Figure 29. A part of a sample of output text file	25
Figure 30. Output plot	25
Figure 31. Search panel of the software	27
Figure 32. NPI blocked sectors for MEX at 0° SA	29
Figure 33. NPI blocked sectors on MEX at 0° solar panel angle	30
Figure 34. NPI blocked sectors for MEX at 0°, 45°, 90° SA	31
Figure 35. NPI blocked sectors for VEX at 0°, 45°, 90° SA	32
Figure 36. NPD blocked sectors for MEX at 0°, 45°, 90° SA	33
Figure 37. NPD blocked sectors for VEX at 0°, 45°, 90° SA	34
Figure 38. ASPERA-MU and NPI sensor	37
Figure 39. ASPERA-MU and NPD sensor	38
Figure 40. Mars Express	39
Figure 41. Functions block diagram	40
Figure 42. Mars Express geometric setting GUI	41
Figure 43. Venus Express geometric setting GUI	41
Figure 44. Search GUI	42

1. Introduction

Mars Express and Venus Express (MEX and VEX) were launched in 2003 and 2005 respectively, orbiting Mars and Venus in an elliptical orbit in order to study our neighbouring planets and to answer fundamental questions about their atmosphere and surface environment. [Ref. 1, 2]

The ASPERA (Analyzer of Space Plasma and Energetic Atoms) instruments, located on each satellite (ASPERA-3 on MEX and ASPERA-4 on VEX) to study the interaction of solar wind and planet atmosphere, are identical. ASPERA Main Unit has 180 degrees of rotation, i.e., it can rotate from 0° to $+180$ degrees around its Z axis to detect particles from different directions. [Ref. 1, 2] (For geometry definition and understanding the coordinate system, see chapter 3 - Geometry)

The purpose of this project is to find out the field of view (FOV) intersections for two ASPERA sensors, called the Neutral Particle Imager (NPI) and the Neutral Particle Detector (NPD), with spacecraft parts such as spacecraft Body, High Gain Antenna and Solar Arrays (SA). It is quite important for scientists to know at which ASPERA Main Unit (ASPERA-MU) scanner angle, NPI and NPD sectors are blocked by MEX and VEX spacecraft parts, mainly to distinguish real particle counts and UV reflections.

With this intention, software was developed in MATLAB to represent MEX and VEX ASPERA geometric data and calculate intersections between NPI and NPDs FOV with spacecraft body, antenna and SA, and to save all the results in a formatted text file and show them on different plots. This was done in a 6-week period as a summer job, and the work done is explained in detail in this report.

2. ASPERA

ASPERA was designed to study the interactions between the solar wind and Mars and Venus atmosphere through Energetic Neutral Atom (ENA) imagers and in-situ plasma measurements. The instrument uses a technique known as “Energetic Neutral Atom Imaging” to visualize the charged and neutral gas environments around Mars and Venus. [Ref. 1, 2]

ASPERA is made up of two main components:

- IMA (Ion Mass Analyzer) mounted separately.
- MU (Main Unit) comprising a Digital Processing Unit (DPU), a Neutral Particle Imager (NPI), a Neutral Particle Detector (NPD) and a Electron Spectrometer (ELS). All were mounted on a scanning platform [Ref. 1, 2].

The experiment is comprised of four sensors:

1. Neutral Particle Imager (NPI)

The NPI sensors survey the ENA fluxes with 32 azimuth sensors of $9.0^\circ \times 11.25^\circ$ angular resolution each.

2. Neutral Particle Detector (NPD)

The NPD sensor extends the ENA images in two additional dimensions, mass and energy. The energy spectrum produced by this sensor supplies direct information about the temperature and plasma bulk velocity in the interaction region and the magnetosphere. It contains two separate detectors (NPD1 and NPD2); each consisting of three sectors with $9^\circ \times 30^\circ$ angular resolution per detector.

3. Electron Spectrometer (ELS)

The ELS provides electron measurements with 16 anodes and $10^\circ \times 360^\circ$ instantaneous field of view.

4. Ion Mass Analyzer (IMA)

The IMA measures ions velocity distribution function with mass separation and with a $4.6^\circ \times 360^\circ$ instantaneous field of view. [Ref. 1, 2]

We focus on NPI and NPDs on the ASPERA Main Unit (ASPERA-MU) to find when their sectors are blocked by different parts of the satellites.

As was discussed briefly, ASPERA-MU is located on MEX and VEX, in different geometric positions on each satellite. The sensors can rotate from 0 to +180 degree around ASPERA-MU Z axis (refer to chapter 2- Geometry, 2.4) and detect neutral particles at those angles. NPI and NPDs as are shown in the Figure 1 as parts of the ASPERA-MU.

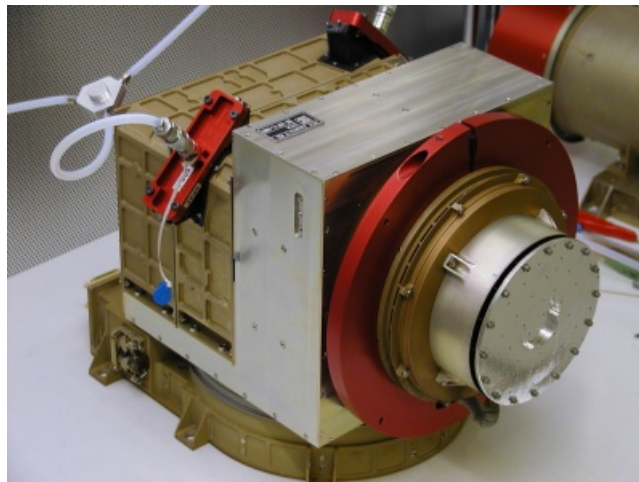

Figure 1. ASPERA-MU and its components [Ref. 9]

3. Geometry

To find NPI and NPDs blocked sectors on MEX and VEX, a coordinate system should be defined and all geometric data must be established in that system. Three main satellite parts whose intersections with NPI and NPD sectors we propose to study are: Satellite Body (spacecraft Body), High Gain Antenna (H.G. Ant) and Solar Panels. Their geometric data and the way that they are located in the coordinate system are defined in the following subsections. Geometric data for both ASPERA-3 and ASPERA-4 were obtained from their design drawings (See Appendix-A). In our 3D model, simplified shapes were assumed thus, the dominant error is from the geometry of the spacecrafts.

3.1. Coordinate system and reference frames

Two different reference frames are defined for both MEX and VEX in their technical manuals; Spacecraft Basic Frame (SBF) and Unit Reference Frame (URF). The SBF is the coordinate system that the spacecraft body is established in (X_{sc} , Y_{sc} , Z_{sc}). According to the MEX and VEX SPICE files, the centre of the SBF is defined at the bottom of spacecraft body, shown in Figures 2 and 3. [Ref. 5, 6]

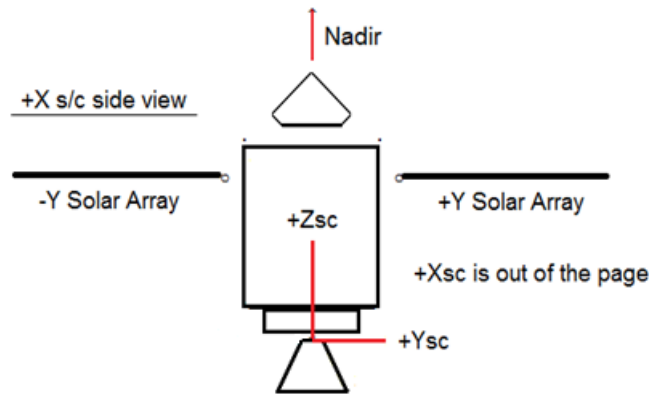

Figure 2A. X side view of the MEX reference frame [Ref. 5]

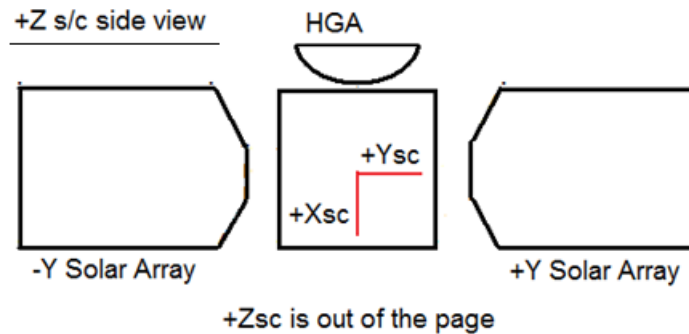

Figure 2B. Z side view of the MEX reference frame [Ref. 5]

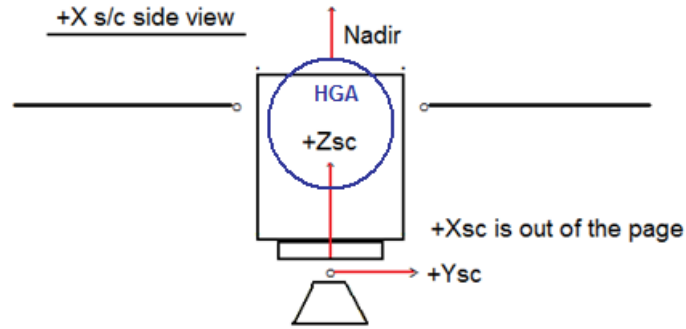

Figure 3A. X side view of the VEX reference frame [Ref. 6]

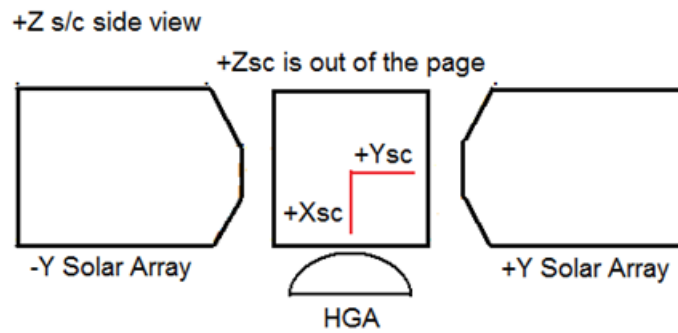

Figure 3B. Z side view of the VEX reference frame [Ref. 6]

Another reference frame is defined for ASPERA-MU, named Unit Reference Frame (URF). The URF is separated from SBF and have different definition for MEX and VEX. This frame is shown in Figures 4 and 5. [Ref. 7, 8]

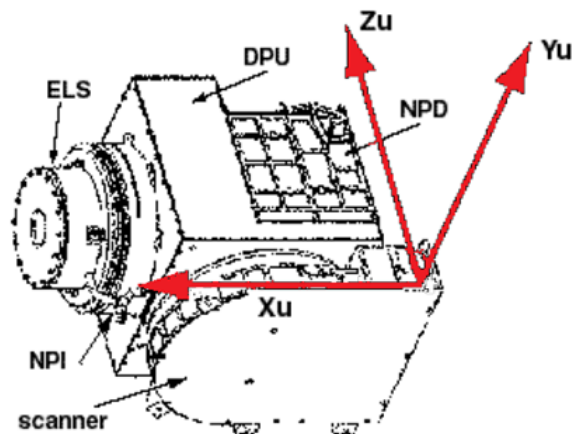

Figure 4. MEX ASPERA-MU reference frame [Ref. 7]

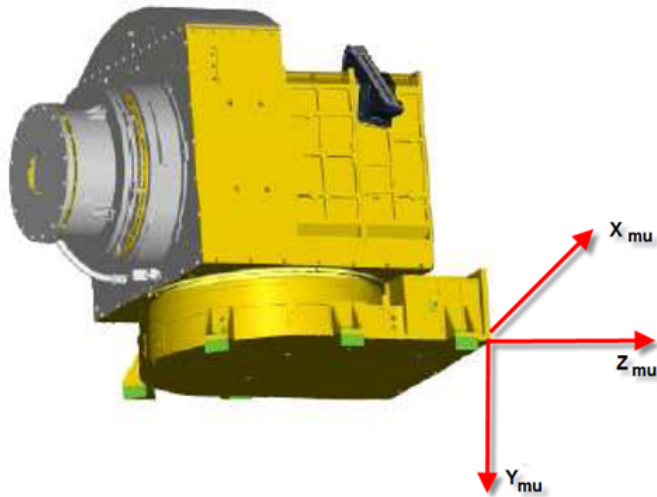

Figure 5. VEX ASPERA-MU reference frame [Ref. 8]

In the software algorithm, a simple Cartesian Coordinate System (CCS) is defined with three major axes, (x , y and z). The reference point of the system is the origin of the CCS and all calculations are based on that point. There is only one coordinate system in the software and all spacecraft instruments are established in that system. More details are given in the following subsections.

3.2. Satellite Body

Assumptions:

- Both MEX and VEX have the same body size.
- Body has a rectangular prism shape. In reality, the side of the MEX body which the High Gain Antenna (HGA) is mounted on is not perpendicular to the other sides, which was not taken into account in our calculations.
- All values are measured in millimeters.

Size:

$1700 \times 1700 \times 1400$ (mm^3) [Hand-measurement from spacecraft drawings]

The centre of the CCS coordinate system is placed at the corner of the body. Figure 6 shows MEX/VEX satellite body in the CCS.

User-defined parameters:

- Reference point (e.g: $[0, 0, 0]$)
- Body size (e.g: $[1700, 1700, 1400]$)

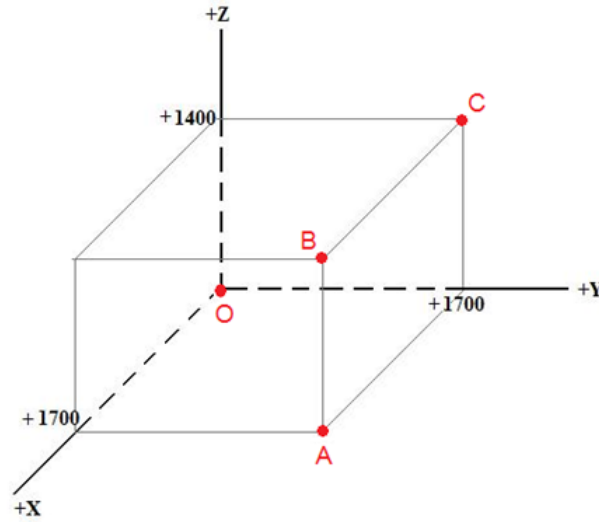

Figure 6. Definition of the coordinate system used in this paper with default setting of spacecraft body parameters.

In the MEX and VEX technical manuals, the centre of body reference frame is located at the centre of the bottom-side while in the software definition, it is located at one vertex of the rectangular prism (see Figure 6).

All spacecraft points have their own definitions based on the defined CCS. For example, the coordinate of points O, A, B and C shown in Figure 6 are as follows:

$$\begin{aligned}
 O &= [0, 0, 0] \\
 A &= [+1700, +1700, 0] \\
 B &= [+1700, +1700, +1400] \\
 C &= [0, +1700, +1400]
 \end{aligned}$$

No difference was made between MEX and VEX spacecraft bodies. Both of them are assumed to have the same size, the same shape and the same geometry.

3.3. High Gain Antenna (HGA)

Assumptions:

- The HGA shape is the same for both MEX and VEX.
- Antenna shape was assumed to be a flat disc.

Size:

Radius:

- MEX: 830 mm.
- VEX: 780 mm.

Thickness: 200 mm.

[Measured by hand from spacecraft plots]

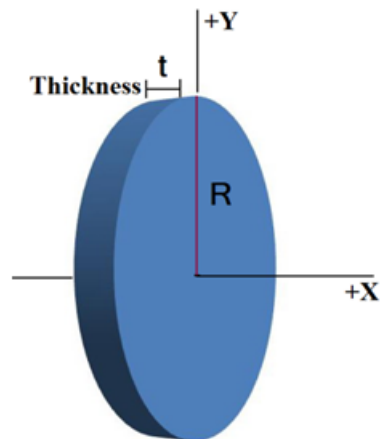

Figure 7. Definition of the H.G. Antenna Disc

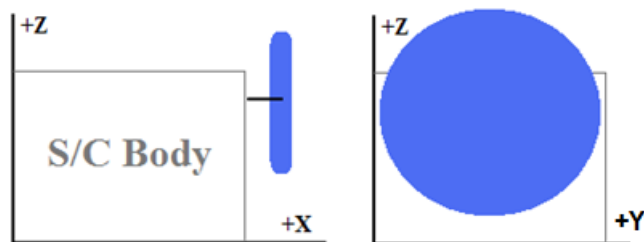

Figure 8. HGA seen from -Y (left) and from +X (right) axes.

User-defined parameters:

- Antenna Centre (e.g: [1950, 850, 1080])
- Radius (e.g:[830])
- Thickness (e.g: [200])

The reference frame of HGA is the same as the spacecraft body and its centre is defined on the basis of that.

3.4. Solar Arrays (SA)

Assumptions:

- Two rectangular prisms are used in the place of the SAs.

Size:

MEX and VEX solar panels have different sizes. As VEX is closer to the sun, the size of solar panels and solar arrays are smaller than those of MEX.

- MEX solar panel size
- VEX solar panel size

Definitions:

- Solar panels for both MEX and VEX are mounted along the Y axis and rotated around it.
- They rotate from -90° to $+90^\circ$. (180° in total, see Figure 10)
- At 0° , solar arrays are parallel to the HGA disc (perpendicular to X axis).
- They rotate clockwise at positive angles.
- The SAs extend all the way to the spacecraft body, which is a simplification. In reality there are mounting brackets between the SAs and the spacecraft body.

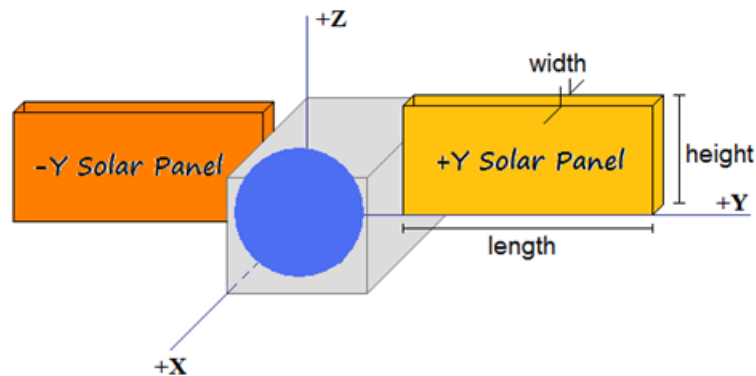

Figure 9. Solar Panels definition on VEX

Width = 50 mm

Length: 4230 mm for MEX

: 2120 mm for VEX

Height = 1800 mm

Solar Panel Angle = 0°

[Measured by hand from spacecraft plots]

The other difference in MEX and VEX solar panels is the definition of +Y and -Y solar panels. In VEX, as is shown in the Figure 9, +Y solar panel is at +Y axis side, while for MEX the +Y solar panel is at the -Y axis side. This naming is confusing but we use it in what follows.

Figure 10 shows the solar panel rotation angle in the XZ plane around the Y axis.

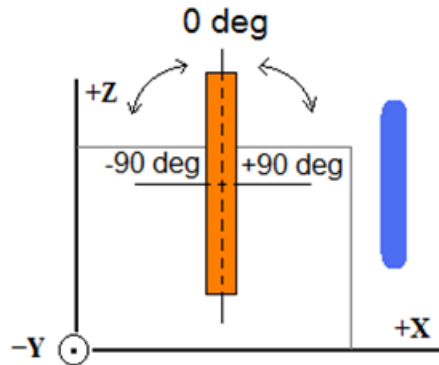

Figure 10. Solar panel rotation angle definition for both MEX and VEX

User-defined parameters:

- +Y solar panel centre (e.g: [850,4465,1200])
- -Y solar panel centre (e.g: [850,-2765,1200])
- Width, length, height (e.g: [50, 4230, 1800])
- Solar panel angle (e.g: [0])

These definitions, the same as HGA and spacecraft body, are based on the main reference frame was defined for whole system.

3.5. ASPERA-MU

ASPERA-MU in the ASPERA technical reports is defined in the different coordinate systems, described in part 2.1. ASPERA-MU and its instruments are defined in the reference frame, the same as spacecraft body. Therefore, all of its geometric data are established in that system.

Assumptions:

- A simple cube is used in the place of ASPERA-MU.
- Both MEX and VEX have the same ASPERA-MU size.
- ASPERA-MU has 180 degrees of rotation, rotates from 0 to +180° around Z-axis.
- It has different locations on MEX and VEX.

Size:

$$256 \times 218 \times 252 \text{ mm}^3$$

[ASPERA plots, Ref. 3]

Definitions:

Since ASPERA-MU is located in different places on MEX and VEX, its rotation differs, and needs to be described separately for MEX and VEX.

ASPERA-MU on MEX:

It is located on the top side of the MEX body at the right corner as is shown in Figure 11.

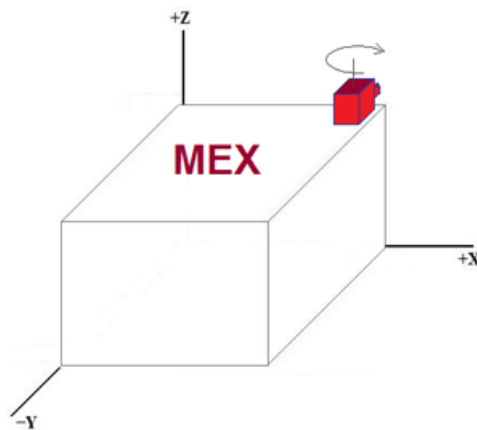

Figure 11. Mounting position of ASPERA-MU for MEX

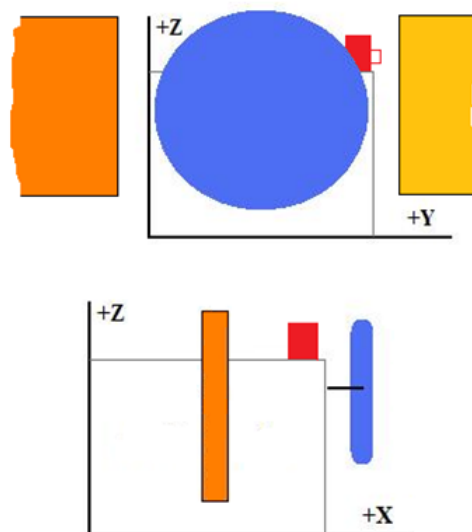

Figure 12. ASPERA-MU location on MEX seen from +X (upper) and -Y (lower) axes

ASPERA-MU on MEX rotates around the Z axis only and its rotation is shown in Figure 13.

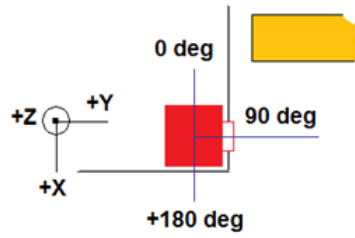

Figure 13- Definition of the MEX ASPERA-MU rotation angle

Figure 14 shows the Unit Reference Frame and ASPERA-MU rotation angle as they are defined in the MEX ASPERA report. [Ref. 7]

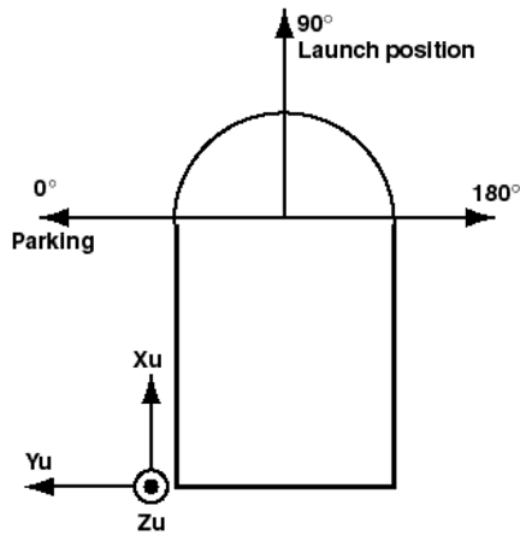

Figure 14. Definition of ASPERA MU rotation angle on MEX in the unit frame. [Ref. 7]

In the software definition, ASPERA-MU rotates around Z axis from its centre point. Then, ASPERA-MU centre point should be defined precisely. This definition is shown by Figure 15.

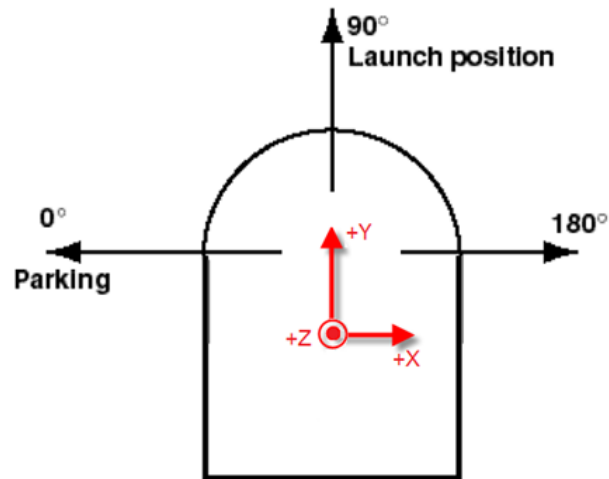

Figure 15. Relation between ASPERA MU rotation angle and the coordinate system defined in the software for MEX.

There is no separated coordinate system for ASPERA-MU. The red arrows in Figure 15 show only the direction of the coordinate system axes.

User-defined parameters:

- ASPERA-MU centre (e.g: [1572, 1591, 1526])
- ASPERA-MU scanner angle (e.g: [0, 180])
- Rotation step (e.g: [+1])

ASPERA-MU on VEX:

It is located on the side of the VEX body, below the solar panel plane as is shown in Figures 16 and 17.

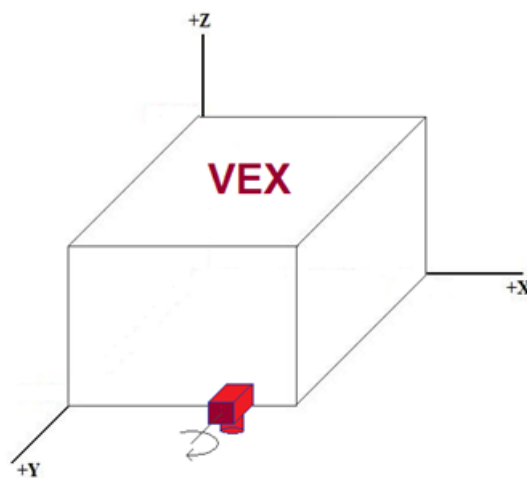

Figure 16. Mounting position of ASPERA-MU for VEX

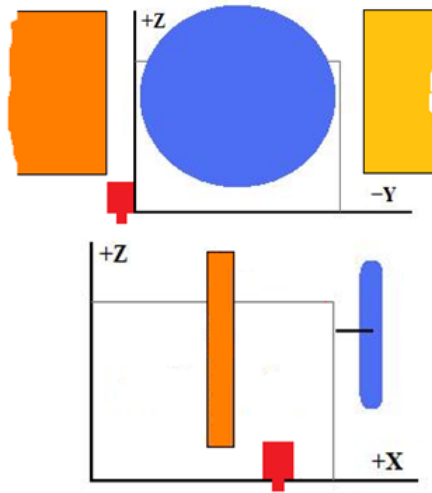

Figure 17. ASPERA-MU location on VEX

ASPERA-MU on VEX rotates around the Y axis only and its rotation is shown in Figure 18.

Figure 18 shows the definition of ASPERA-MU rotation angle and its centre of rotation on VEX as is defined in the software.

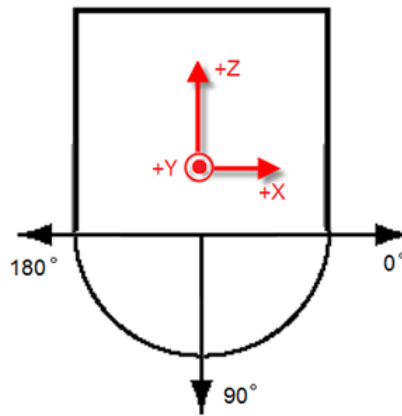

Figure 18. Relation between ASPERA MU rotation angle and the frame axes defined in the software for VEX.

User-defined parameters:

- ASPERA-MU centre (e.g: [1278, -126, 109])
- ASPERA-MU scanner angle (e.g: [0, 180])
- Rotation step (e.g: [+1])

3.6. NPI

As mentioned before, NPI has 32 sectors, mounted around a disc with specific radius and thickness. These sectors, as we see in Figure 19, have inner and outer apertures and there is a small gap between each of them. Inner apertures, as well as outers, are located around a disk but with shorter radius compared to the outers.

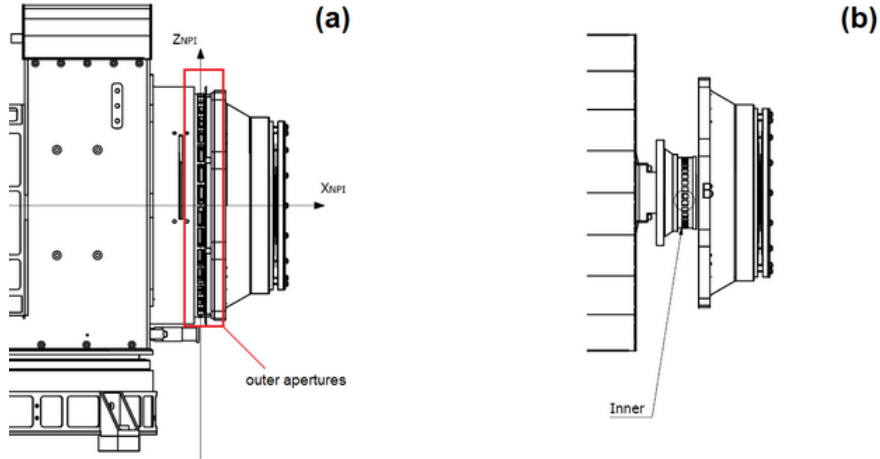

Figure 19. (a) NPI outer aperture. (b) NPI inner aperture [Courtesy Magnus Oja].

A different model was defined for the NPI plane in the 3D model but it does not influence the output results.

Assumptions:

- NPI is assumed as a disc.
- It has 32 sectors; all have the same angular resolution.
- NPI rotates in the same way as the ASPERA-MU.
- The gaps between each sector were neglected.
- Instead of inner aperture, a single point at the center of NPI plane was defined as focal point.

Size:

FOV: $9^\circ \times 11.25^\circ$ per sector [plots and Ref. 1]

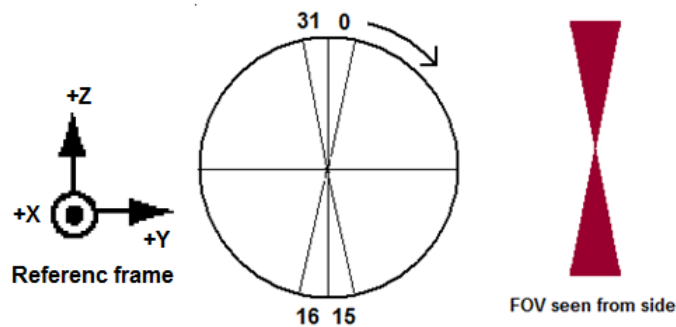

Figure 20. Definition of FOVs of NPI for MEX and VEX and their numbering.

Definitions:

For each NPI sector, 5 sample points are defined. One at the centre and 4 at the corners, located outside of the sectors because of the NPI response function. These points are used to find intersection between each sector and satellite parts. The line of sight is drawn from the centre of NPI to any of those points and continued with a specific step length until an intersection is found or spacecraft confines are exceeded.

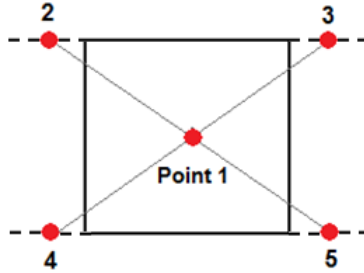

Figure 21. Sample points for each NPI sector

User-defined parameters:

- NPI centre (ex: [1410, 1591, 1526])
- NPI radius (ex: [76mm])
- Number of sectors (sensors)
- Angular Resolution of Field Of View (ex: [9°])

Since NPI has a special FOV, the sample points look at different directions depending on the ASPERA-MU scanner angle. In the default settings, we assumed NPI with 9° field of view and 76 mm radius. The sample points in one sector are located as follows:

$$\theta = 9^\circ, \quad R=76 \text{ mm}, \quad \alpha = 11.25^\circ$$

$$t = 2R\sin(\theta/2) = 11.92 \sim 12\text{mm}$$

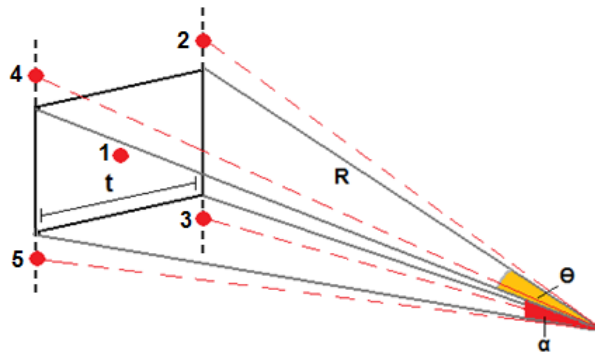

Figure 22. Parameters used to define the FOV for NPI

3.7. NPDs

NPD, the same as NPI, has inner and outer aperture with completely different and complicated structure compared with NPI sectors. We do not go into the details of the NPD design but first of all, the whole NPD1 and NPD2 sectors have 168.6° field of view with respect to the center of NPD inner apertures (which means 84.3° per each NPD instead of 90°).

Under our assumptions, we neglected this difference between FOVs and also tried to simplify our model as described below.

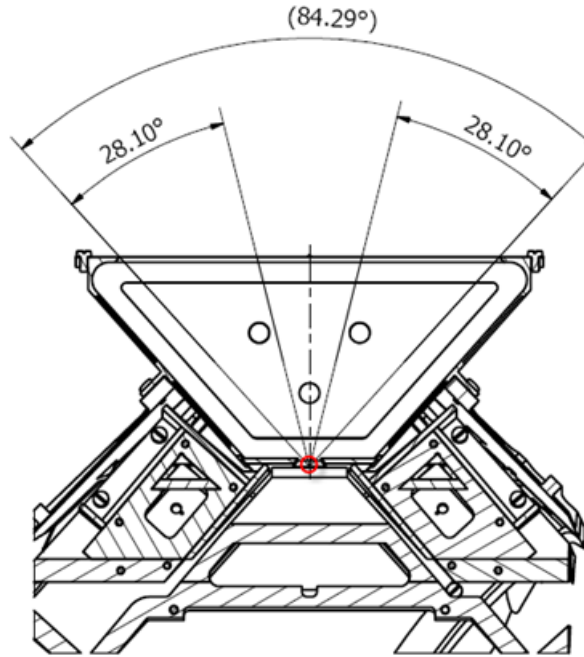

Figure 23. NPD FOV and its focal point. (See Appendix A) [Courtesy Magnus Oja].

Assumptions:

- Two flat planes at the top side of ASPERA-MU; one to the left and the other to the right side.
- Each NPD has 3 sectors; all have the same angular resolution.
- Assumed a focal point in the place of inner aperture at the bottom center of each NPD.

Size: Length= 56 mm

FOV= $9^\circ \times 30^\circ$ per sector [plots and Ref. 1, 2]

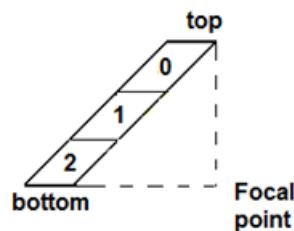

Figure 24. Definition of NPD sensor numbering.

Definitions:

- In MEX and VEX, both NPDs are located at the top of the ASPERA-MU and tilted in 2 directions with some angles. These angles are user-defined in the software and can be changed easily. According to our assumptions, the NPD plane is tilted by 45° around the X axis and by 15° around the Z axis.

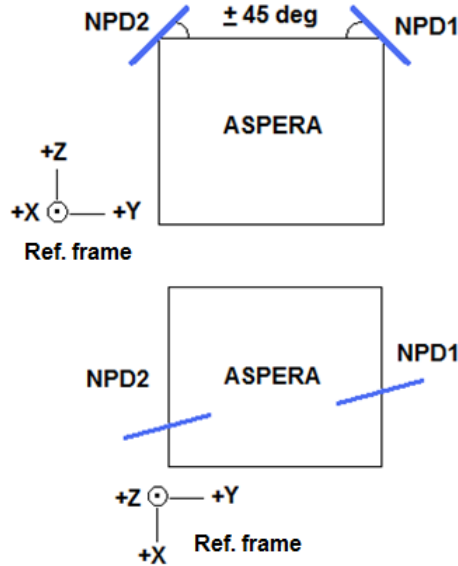

Figure 25. NPD tilt angles

- For each sensor, 9 sample points are defined, one at the centre and the others at the edges, located in the same plane as the centre points. The line of sight is drawn from the focal point to these sample points to find intersections with the satellite.

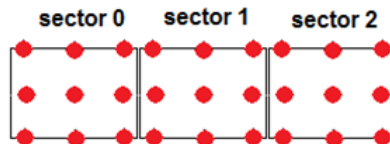

Figure 26. Definition of NPD sample points

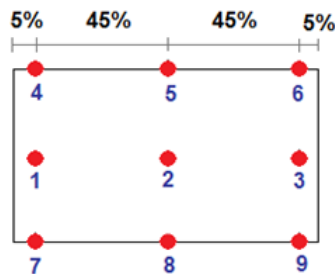

Figure 27. Definition of NPD sample points order and their locations in one NPD sector

- Sectors on each NPD are numbered from the top to the bottom. The topmost sector is numbered as 0 and the bottommost as 2. (See Figure 24)
- To find accurate places for NPD sectors, a cube is assumed with the size of NPD length. 9 sample points are placed on one side of the cube and the focal point is placed at the centre of the cube.

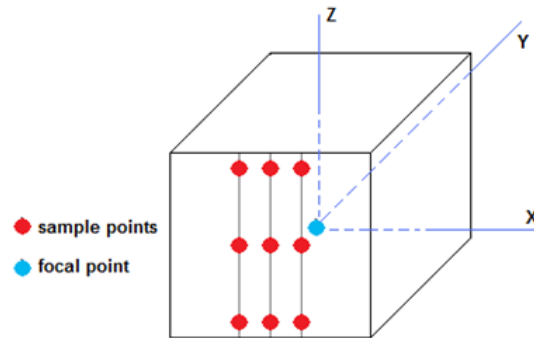

Figure 28. NPD sample points

The distance between points on the X axis is calculated by NPD field of view. Finally all points are rotated around the centre (focal point) by the defined tilt angle. (45° around X axis and 15° around Z axis)

With this method, accurate positions for NPD sample points are found.

User-defined parameters:

- Focal point.
- Field of view.
- NPD Length.
- NPD tilted angles.

4. Algorithm and outputs

To compute NPI and NPD obstructions with MEX and VEX, a simplified algorithm is used as described below.

The software reads all settings from XML files and figures out the locus of all instruments (See Appendix-D). A sphere of large radius is assumed around the whole system in such a way that all satellite parts are located inside it. Its radius is large enough to encompass all spacecraft instruments for different rotation angles. This sphere is defined as the physical infinity of our calculations. When the line of sights (LOS) from NPI and NPD sectors reach to that sphere, calculation is stopped for that specific sector and ASPERA-MU scanner angle.

According to the user settings, spacecraft body and antenna are fixed in their places. As they are not rotating or moving during calculation, finding intersections with these two are easy. After those are fixed in their places, solar panels should be placed in their places. Before calculating intersections with different sectors, they must be rotated around the Y axis for the defined SA angle, but as they are not located at the centre of coordinates, they have to first be transferred to the centre, then rotated around Y axis and finally moved back to their original centre.

The problem above is the same for ASPERA-MU, NPI and NPD, but it is solved differently. For these, ASPERA-MU centre is defined as the centre of coordinates because they rotate around the Z axis of the ASPERA-MU centre. All points are then transferred to the ASPERA-MU centre, rotated around Z or Y axis (depends on satellite; for MEX they should be rotated around Z while for VEX rotated around Y axis) and moved back to their origin.

For all 180 degree ASPERA-MU scanning angles and for all sample points for each NPI and NPD sectors, a line of sight is drawn to the large radius sphere. For NPI sectors, this line starts from NPI centre and for NPD from NPD focal point. A small value is defined as the step length of LOS. For each step per each sample point, the software compares the coordinate of that point with the MEX or VEX mechanical part coordinates. If it finds that point is located inside one of those satellite parts, the intersection is stored for detected ASPERA-MU scanner angle and that NPI or NPD sector in an array.

In our software algorithm, '1' is stored in the array when the line of sight is blocked by spacecraft body, '2' for antenna, '3' for +Y solar panel and '4' for -Y solar panel. If no intersection is found, it writes '0' in the array cells.

In our default settings, the NPI array is $181 \times 32 \times 5$; has 181 rows to cover all ASPERA-MU scanner angles from 0° to 180° , 32 columns for 32 NPI sectors and 5 layers for 5 sample points. The structure is almost the same for NPD, but it has a $181 \times 3 \times 9$ matrix, because of the difference in the number of sectors and number of sample points.

Finally, if there is an intersection with one or more of those sample points with any part of MEX or VEX, that sensor is assigned as a blocked sector for that ASPERA-MU scanner angle.

The output of our calculation is saved in a text file with a special file format as shown in Figure 29.

```

/*
/*
/* Column 1 represents the angle of ASPERA
/* Column (2) to (33) represent (MEX_NPI) sector numbers
/******
/*
/*
/*CR S00 S01 S02 S03 S04 S05 S06 S07 S08 S09 S10 S11 S12 S13 S14 S15 S16 S17 S18 S
/*-----
0 0 0 0 0 0 0 0 0 1 1 1 1 1 1 1 1 1 1 1 1
1 0 0 0 0 0 0 0 0 3 1 1 1 1 1 1 1 1 1 1 1 1
2 0 0 0 0 0 0 0 0 3 1 1 1 1 1 1 1 1 1 1 1 1
3 0 0 0 0 0 0 0 0 3 1 1 1 1 1 1 1 1 1 1 1 1
4 0 0 0 0 0 0 0 0 3 1 1 1 1 1 1 1 1 1 1 1 1
5 0 0 0 0 0 0 0 0 3 3 1 1 1 1 1 1 1 1 1 1 1
6 0 0 0 0 0 0 0 0 3 3 1 1 1 1 1 1 1 1 1 1 1
7 0 0 0 0 0 0 0 0 3 3 1 1 1 1 1 1 1 1 1 1 1
8 0 0 0 0 0 0 0 0 3 3 1 1 1 1 1 1 1 1 1 1 1
9 0 0 0 0 0 0 0 0 3 3 1 1 1 1 1 1 1 1 1 1 1
10 0 0 0 0 0 0 0 0 3 3 1 1 1 1 1 1 1 1 1 1 1
11 0 0 0 0 0 0 0 0 3 3 1 1 1 1 1 1 1 1 1 1 1
12 0 0 0 0 0 0 0 0 3 3 1 1 1 1 1 1 1 1 1 1 1

```

Figure 29. A part of a sample of output text file.

From Figure 29, we see that the columns represent the number of sectors and the rows are ASPERA-MU scanner angle.

Plotting the result is the other way to show the outputs. In Figure 30, one can easily recognize the blocked sectors with satellite parts.

In the calculation algorithm, if the LOS has any intersection with spacecraft body, it will not find the intersection for that sector with antenna. It consequently finds the intersection either with spacecraft body or with High Gain Antenna.

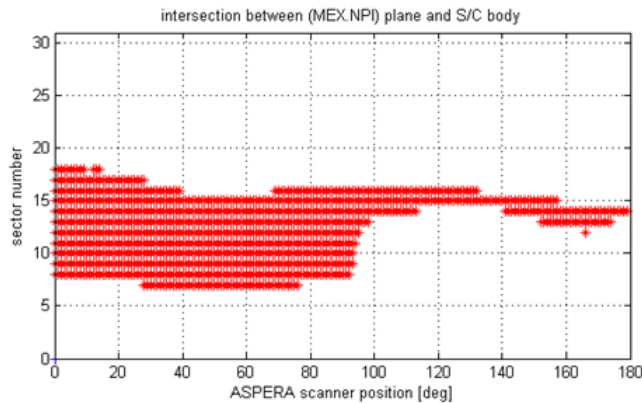

Figure 30. Output plot. NPI blocked sectors on MEX with spacecraft body. Horizontal axis represents ASPERA-MU scanner angle, which starts from 0° and ends at 180° . NPI sector numbers are shown on vertical axis. The intersected sectors for different ASPERA-MU scanner angles are shown by red dots.

It can be seen clearly from Figure 30 that some sectors are blocked. For example, sector 15 for most of the scanning angles is blocked by the spacecraft body even when ASPERA-MU is located at 90° . Although at 90° the NPI plane is parallel to the spacecraft body, some sample points which are located at the edges can still have an intersection with the body. Therefore, geometric definitions are important, because if the NPI FOV is changed from 9° to 2° , there will not be any intersection between sector 15 and spacecraft body at 90° .

Two different types of plots can be obtained from the software. The first type is a plot, divided into 4 smaller plots, each showing intersections of NPI or NPD with one part of MEX or VEX separately. The second type shows intersection with all satellite items in one plot by using different colours to separate the results.

Another function called “blocked” was written in C language. This function can read the output files of simulation and return the blocked condition for any sensor at any scanner angle. This function is available to download from:

<http://www.irf.se/software/>

5. Software structure

The software was built in MATLAB R14 with all geometry data of the main parts of MEX and VEX (body, high gain antenna, solar arrays), as well as ASPERA-MU position, to calculate intersection between NPI and NPDs sensors with these parts for different ASPERA-MU scanner positions and SA angles. The output is in text file format, and consists of scanner position, sector number and intersection with satellite parts. Additionally, a function reads all the data from the text file and sketches plots to clearly show intersections. Figure 41 in Appendix-C shows the schema of software functions and their relations briefly, in addition to the whole software structure.

A GUI was built to facilitate running functions interactively. A user can modify settings and save them. Also he/she can run different modules to find obstructions in NPI and NPDs for ASPERA-3 and 4. Also, another GUI was made in order to search different results (Figure 31)(See Appendix-D).

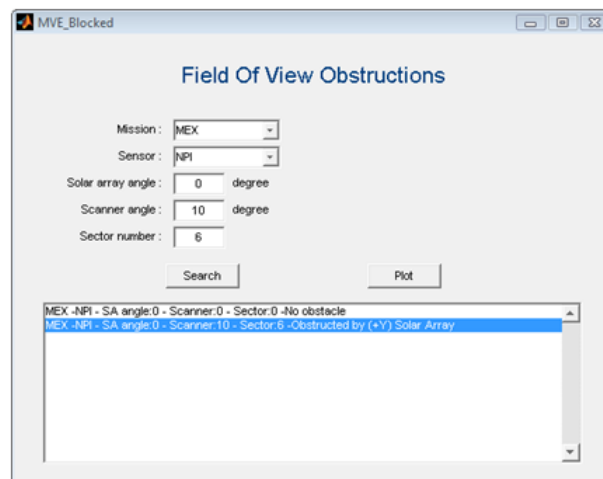

Figure 31. Search panel of the software. By this panel users can specify the mission, sensors, SA angle, scanner angle and sector number and search for blocked sectors.

5.1. Public functions

Some functions were made as public to be used at any time. These functions can be categorized to two groups:

- I/O functions
- Math functions

I/O functions contain 2 files for reading and writing from/to XML file and are called “xml_read.m” and “xml_write.m” respectively.

Math functions contain three files:

1. “Rotation_Matrix.m”

This function given the rotation axis and rotation angle, returns the Euler Rotation Matrix.

2. “Rotation_Around_Origin.m”

The function gives a vector and rotates it around any given vectors, and returns the rotated vector.

3. “Transfer_Matrix.m”

It transfers a vector from its old origin to a new origin/centre.

5.2. Setting functions

Since the user can define all the settings for the MEX and VEX instruments, two GUIs were built to get all data separately and store them in two XML files. User has the ability to change all the settings.

5.3. Calculation routines

NPI and NPD intersections are calculated by two functions (“Calc_NPI_Intersection.m” and “Calc_NPD_Intersection.m”). These two functions get all settings first by other functions called “Gen_NPI_Sector_Points.m” and “Gen_NPD_Sector_Points.m”; and then generate NPI and NPD sample points. Finally intersections are found between those points and stored in a 3D arrays. This array is returned to the main function.

5.4. Output functions

Returned array from calculation functions is stored in a text file with specific format. “txt_write.m” gets this array and saves it in a text file. “Plot_MVE.m” can read stored data from text file and present intersection plots.

6. Results

Some of the results obtained from MATLAB are shown below and one of them is explained in detail:

1) NPI blocked sectors for MEX at 0° SA:

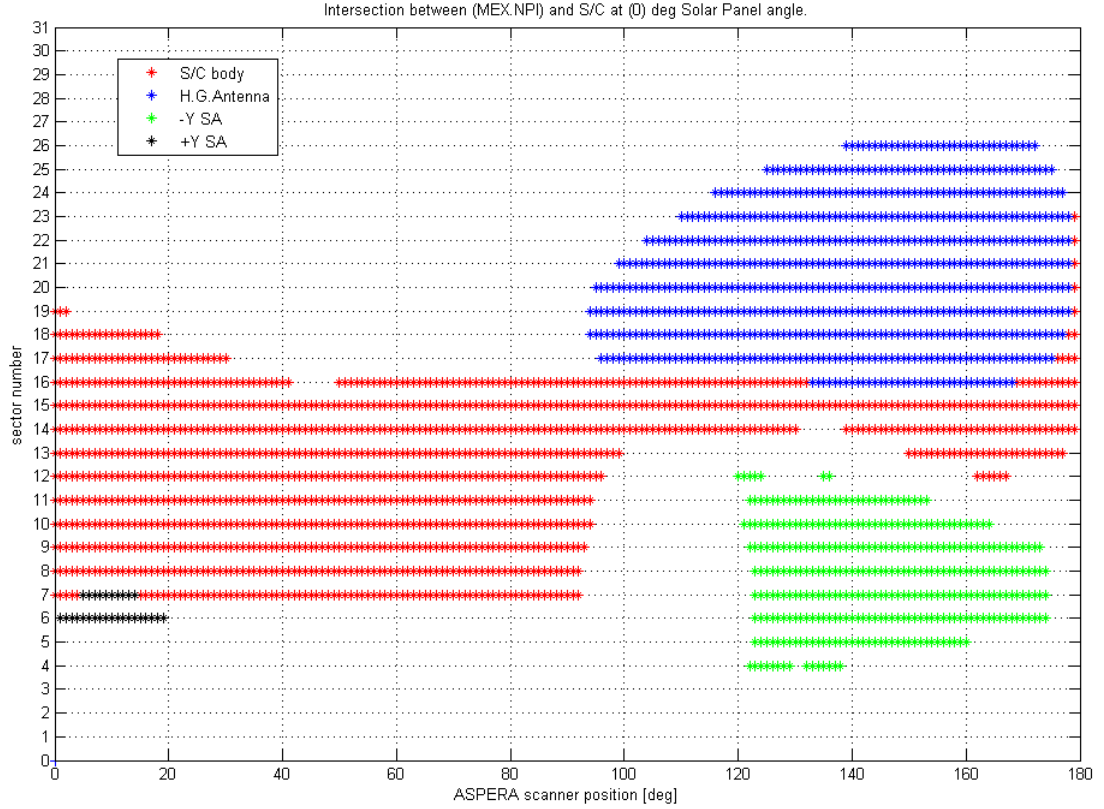

Figure 32. NPI blocked sectors for MEX at 0° SA

The number of NPI blocked sectors by MEX spacecraft for different ASPERA-MU scanner angles are shown in Figure 32. ASPERA-MU scanner angles are represented on X axis, and NPI sectors on Y axis.

In general, blocked sectors by spacecraft body and antenna (shown by red and blue dots respectively) are constant for different solar panel angles, since they do not move or rotate. The blocked sectors only change with different solar panel angles.

Since the NPI is located at the top of MEX, when ASPERA-MU scanner is at 0° , some of the sectors intersect with spacecraft body. While NPI rotates with ASPERA-MU from angle 0 to $+90^\circ$, because some of the sectors are going out of the body confines, the numbers of blocked sectors are decreased. In this interval ($[0^\circ, +90^\circ]$), because the antenna is located at the back of the NPI plane, there is no intersection between any of NPI sectors with antenna. Since the solar panel angle is at 0° , and because the panel thickness is small, only some of the sectors intersect with the $+Y$ solar panel,

mainly because of the angular FOV of the sectors. In our simulation, when the FOV was reduced from 9° to 3° , the intersections between these sectors and $+Y$ solar panel at 0° scanner angle disappeared.

When ASPERA-MU is located at $+90^\circ$, NPI plane is out of the spacecraft body confines. We know that the NPI plane is perpendicular to the spacecraft body top-side plane, and so no intersection between sectors and body is expected. Again, by increasing angular FOV from 3° to its actual value (9°), three sectors located at the bottom of NPI plane intersect with the body (sector numbers 14, 15 and 16).

While ASPERA-MU scanner rotates from $+90^\circ$ to $+180^\circ$, the sectors which are located at the left of the NPI plane (sector numbers 15 to 26) intersect with the antenna, and some sectors at the right side (numbers 4 to 11) intersect with $-Y$ solar panel.

Figure 33 shows NPI plane while SA is at 0° for each MEX spacecraft parts.

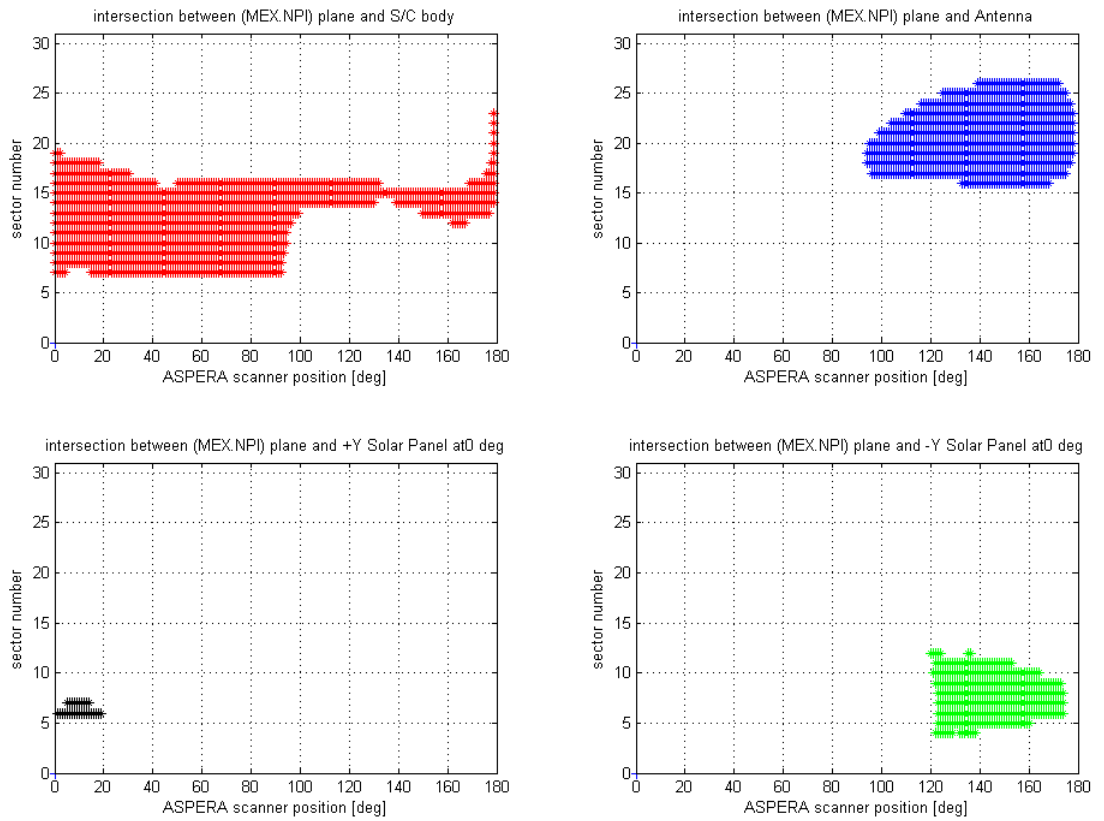

Figure 33. NPI blocked sectors on MEX at 0° solar panel angle.

2) NPI blocked sectors for MEX.

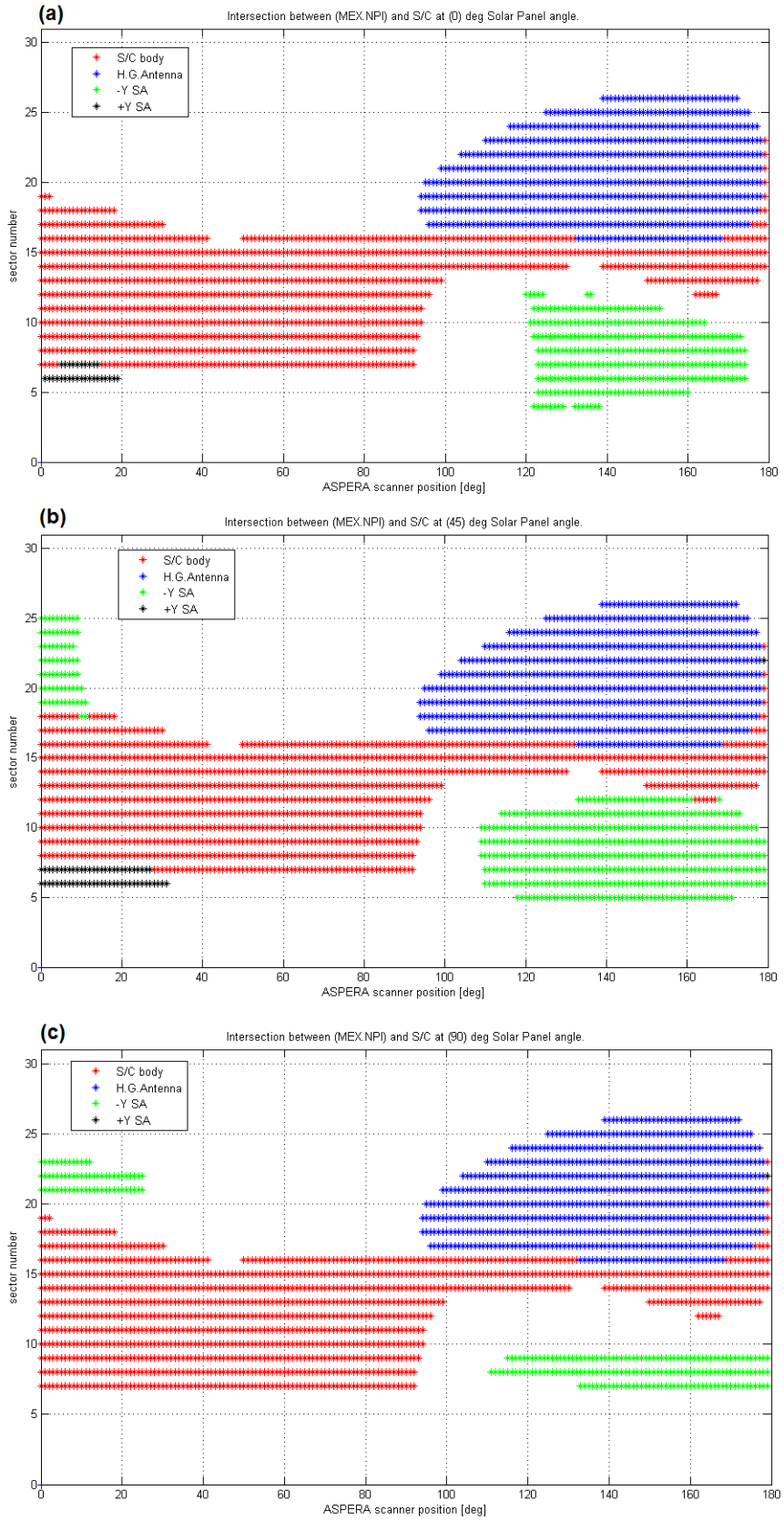

Figure 34. NPI blocked sectors for MEX at (a) 0°, (b) 45° and (c) 90° SA

3) NPI blocked sectors for VEX.

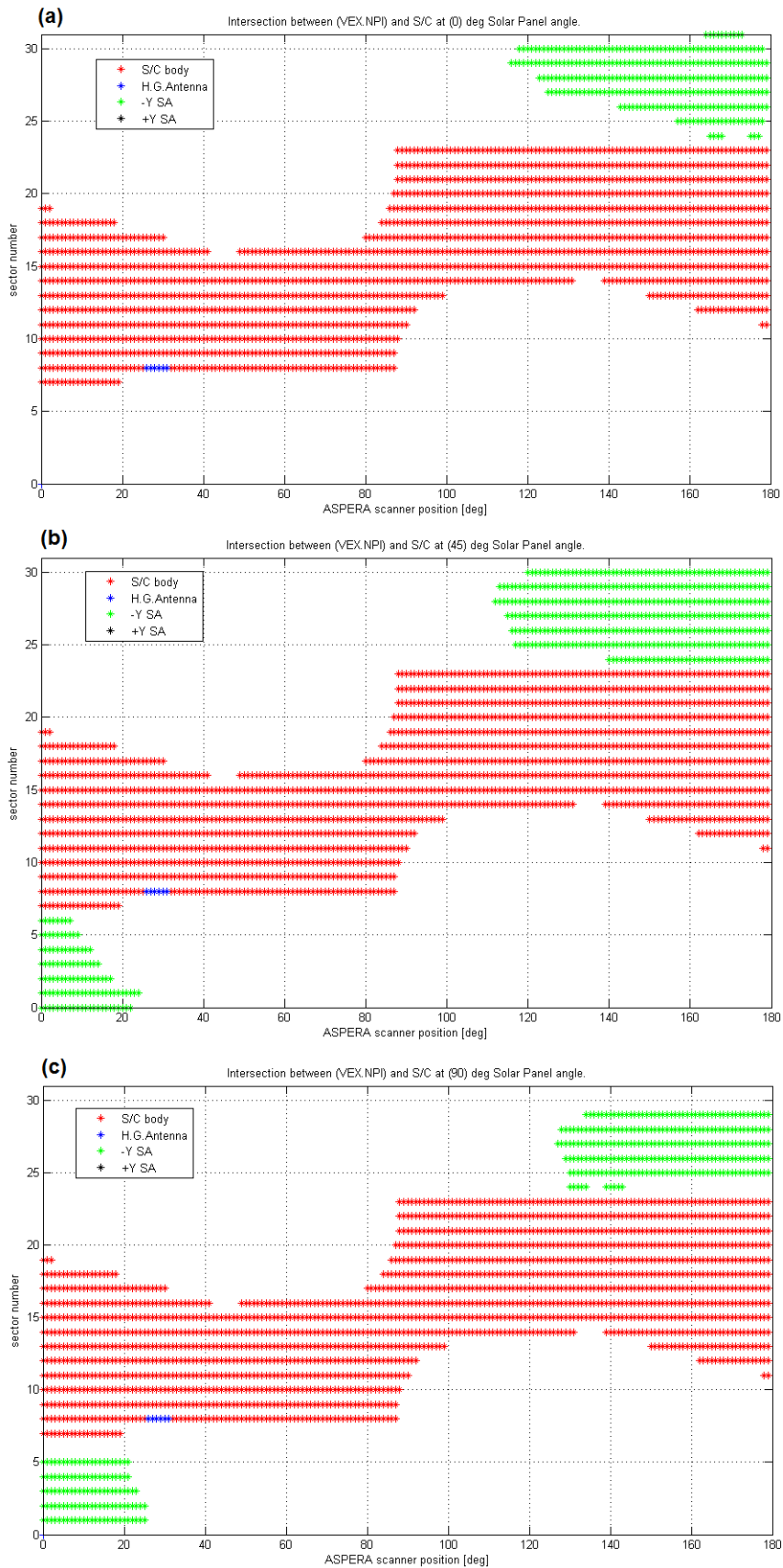

Figure 35. NPI blocked sectors for VEX at (a) 0°, (b) 45° and (c) 90° SA

4) NPD blocked sectors for MEX.

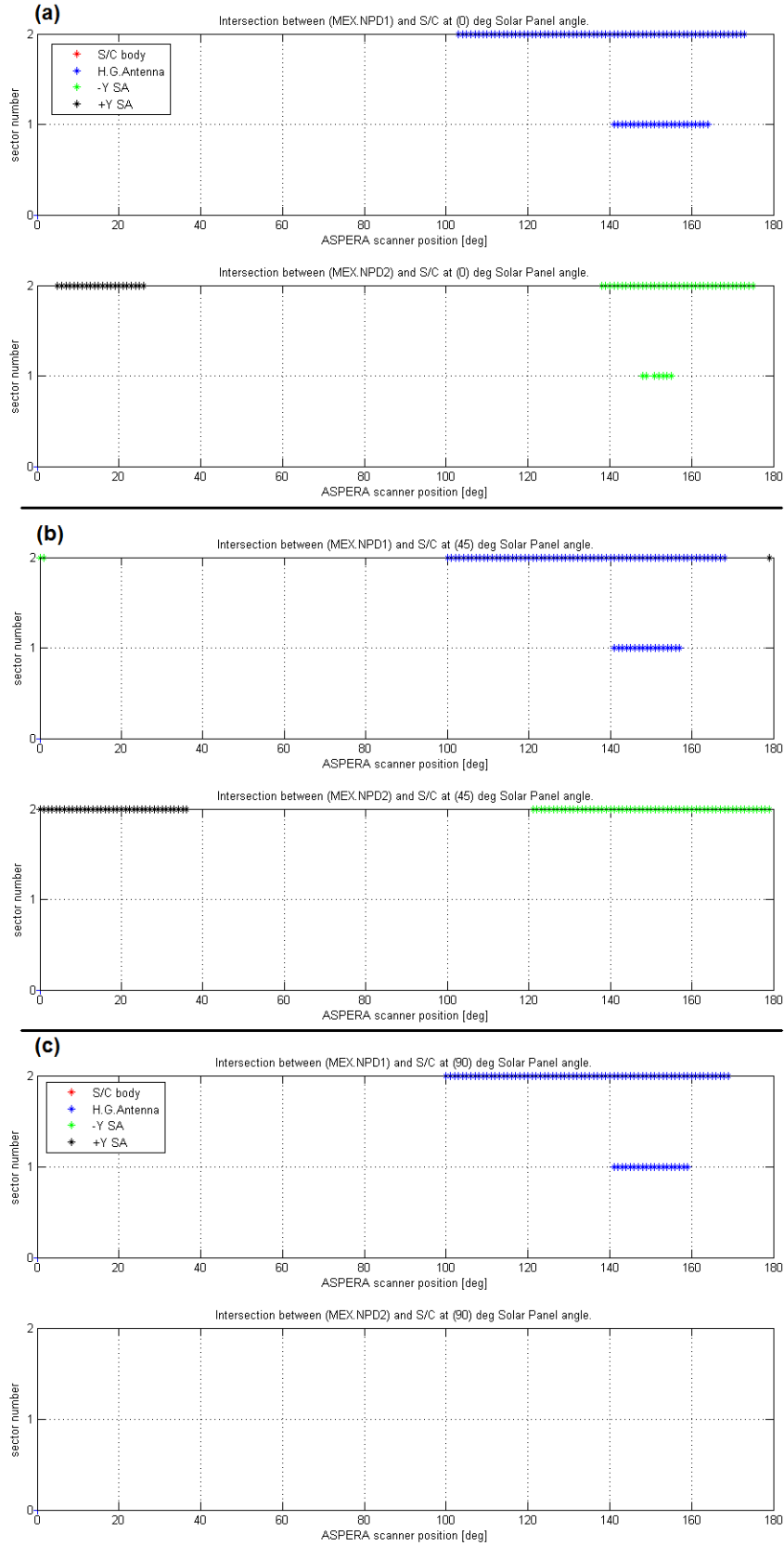

Figure 36. NPD blocked sectors for MEX at (a) 0°, (b) 45° and (c) 90° SA

Top panel on each figure shows NPD1 and bottom panel shows NPD2 blocked sectors

5) NPD blocked sectors for VEX.

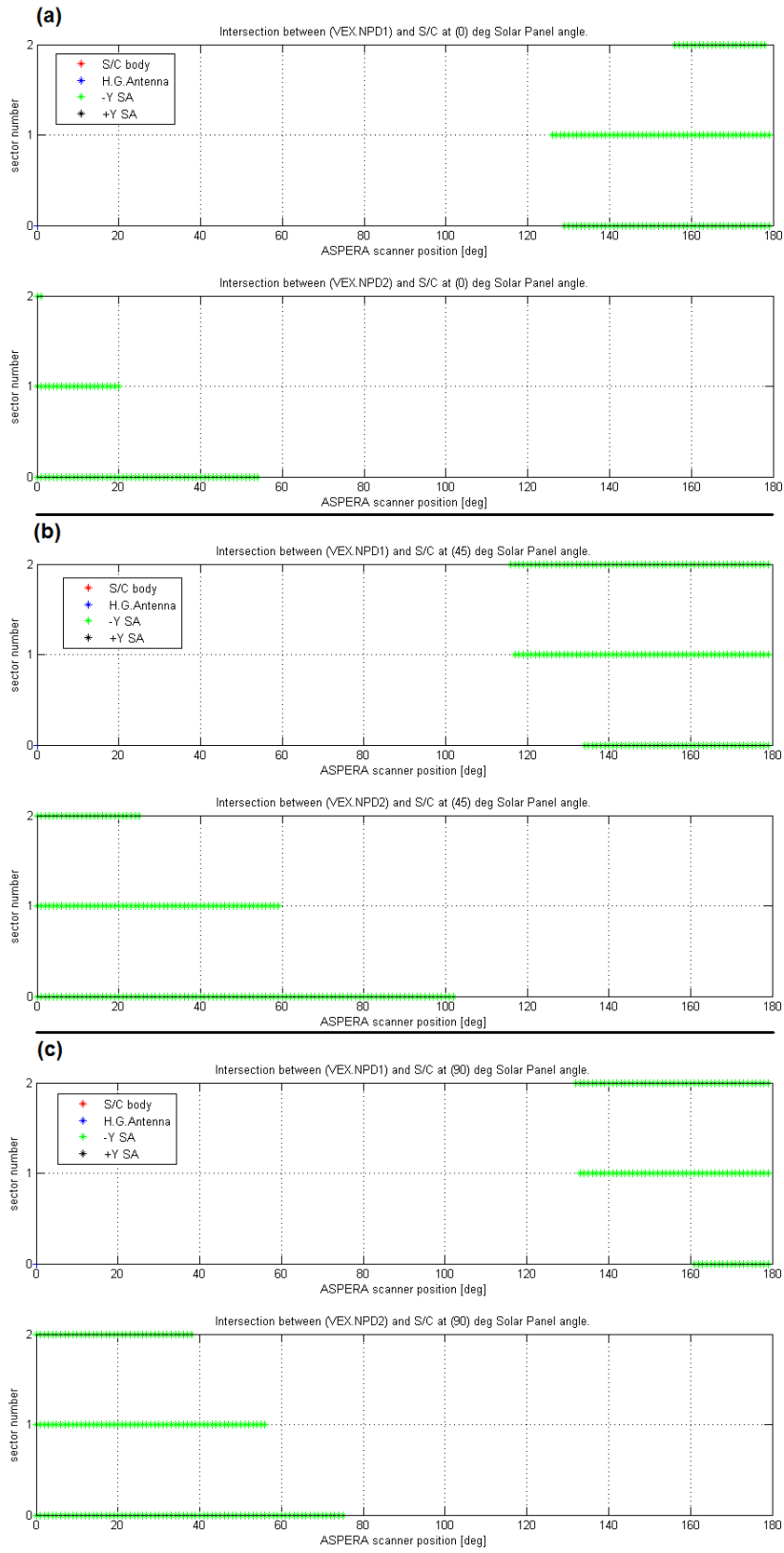

Figure 37. NPD blocked sectors for VEX at (a) 0°, (b) 45° and (c) 90° SA

Top panel on each figure shows NPD1 and bottom panel shows NPD2 blocked sectors

7. Summary

NPI and NPD sectors on ASPERA-MU are blocked by MEX and VEX spacecrafts at different ASPERA-MU scanner angles. These blocked sectors are related to the geometry of MEX and VEX.

On each NPI and NPD sector, according to geometric definitions, sample points are defined in software. For each sample point, a line of sight is drawn from the centre of NPI or NPD to that point, and continued with chosen step length to a physical infinity. For each step, the software checks the intersection with different satellite parts.

All intersected sectors for different ASPERA-MU angles are stored in a 3D array and the results are saved into a text file and may also be plotted. These routines are done in our software by functions in MATLAB.

8. Future work

1. MEX and VEX geometries were simplified for analysis, as described in assumptions in part 2. Spacecraft body is not completely a cube, antenna is not a disc and solar panels have parallelogram connectors, but disk assumption for HG antenna seems reasonable.
2. Increasing the number of sample points for both NPI and NPDs to get more accurate results.
3. Finding more accurate geometric data for MEX and VEX to get more reliable results.
4. Only one side of the solar panels is covered by solar arrays. It could be important to determine if the intersection with the solar panel is with the side that is covered by the solar arrays or not. Since only the “array covered side” should give UV effects and in our algorithm there is no distinction between the solar panel sides, the results could be more useful if the solar panel sides can be distinguished. This method can be extended to our algorithm without changing the software main structure.
5. This work can be extended for IMA and ELS.

Appendix-A

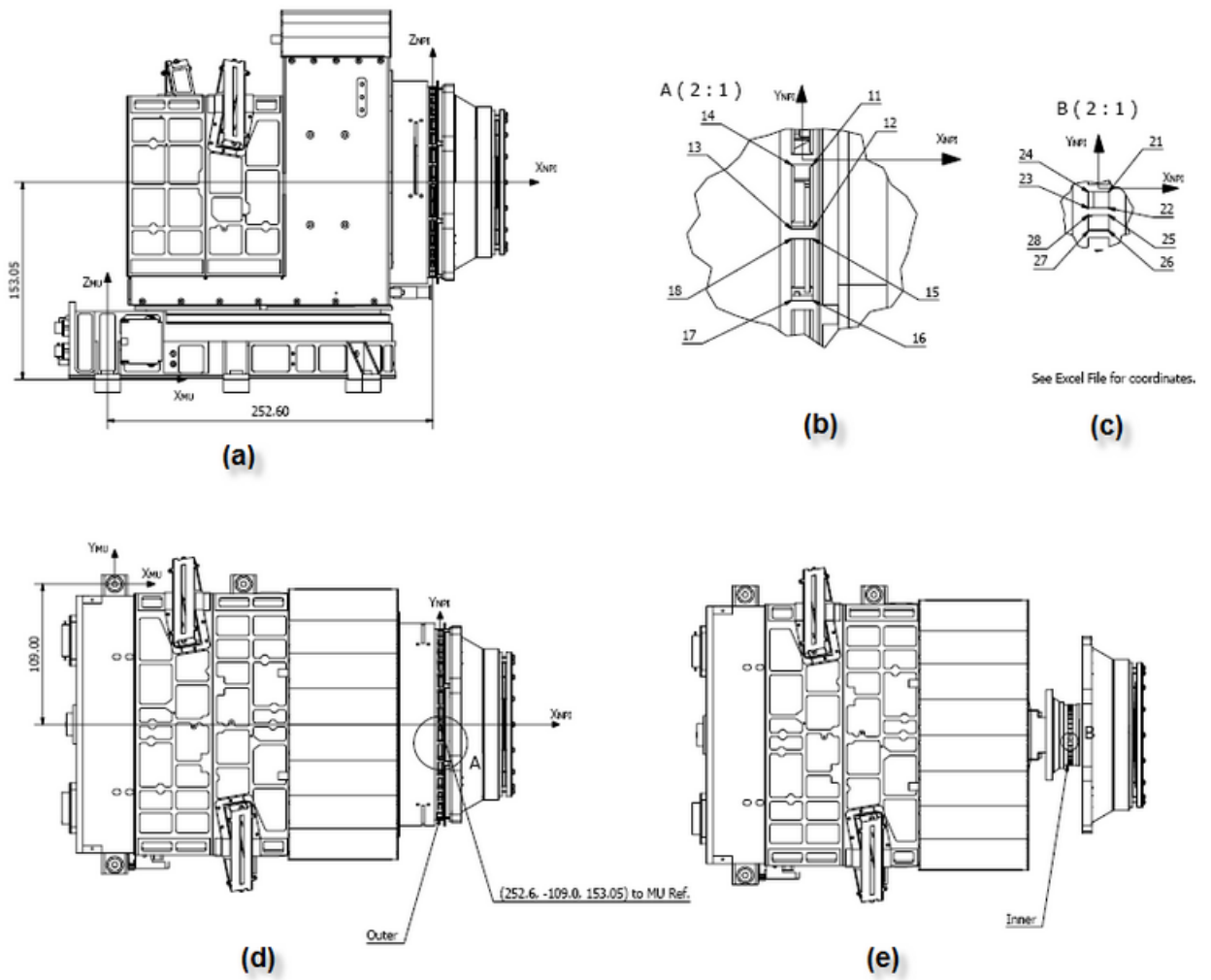

Figure 38. ASPERA-MU and NPI sensor [Courtesy Magnus Oja].

Figure 38 (a) and (d) show the ASPERA-MU with its specified dimensions. Figures 38-(b) and (c) zoom into the parts of the NPI sectors marked by circles in Figure 38-(d) and (e).

Figure 38-(b) and (c) show the NPI outer and inner apertures respectively, and different numbering systems are used to show the corners of each sector, whose exact geometry is listed in table A.

Table A– NPI outer and inner apertures geometry

Outer	X	Y	Z
11	2.100	-1.000	73.993
12	2.100	-13.455	72.767
13	-2.100	-13.445	72.767
14	-2.100	-1.000	73.993
15	2.100	-15.416	72.376
16	2.100	-27.392	68.744
17	-2.100	-27.392	68.744
18	-2.100	-15.416	72.376

Inner	X	Y	Z
21	1.900	-0.696	23.390
22	1.900	-3.881	23.076
23	-2.100	-3.881	23.076
24	-2.100	-0.696	23.390
25	1.900	-5.246	22.804
26	1.900	-8.308	21.876
27	-2.100	-8.308	21.876
28	-2.100	-5.246	22.804

Table (A) shows the exact geometry of the NPI outer and inner apertures relative to the NPI reference frame, found from the ASPERA technical design files (the NPI reference frame is shown in Figure 38-(a) and (d)).

Figure 39 shows the ASPERA-MU, NPD1 and NPD2.

NPD2 is highlighted in circle A of Figure 39-(a), and its sensor corners are marked by numbers 1 to 8. The center of the inner aperture is shown by the point numbered as 9. Figure 39-(c) shows the NPD field of view relative to the central aperture point. NPD1 and its sensor geometries are depicted in Figure 39-(d) and (e), which are the same as in NPD2.

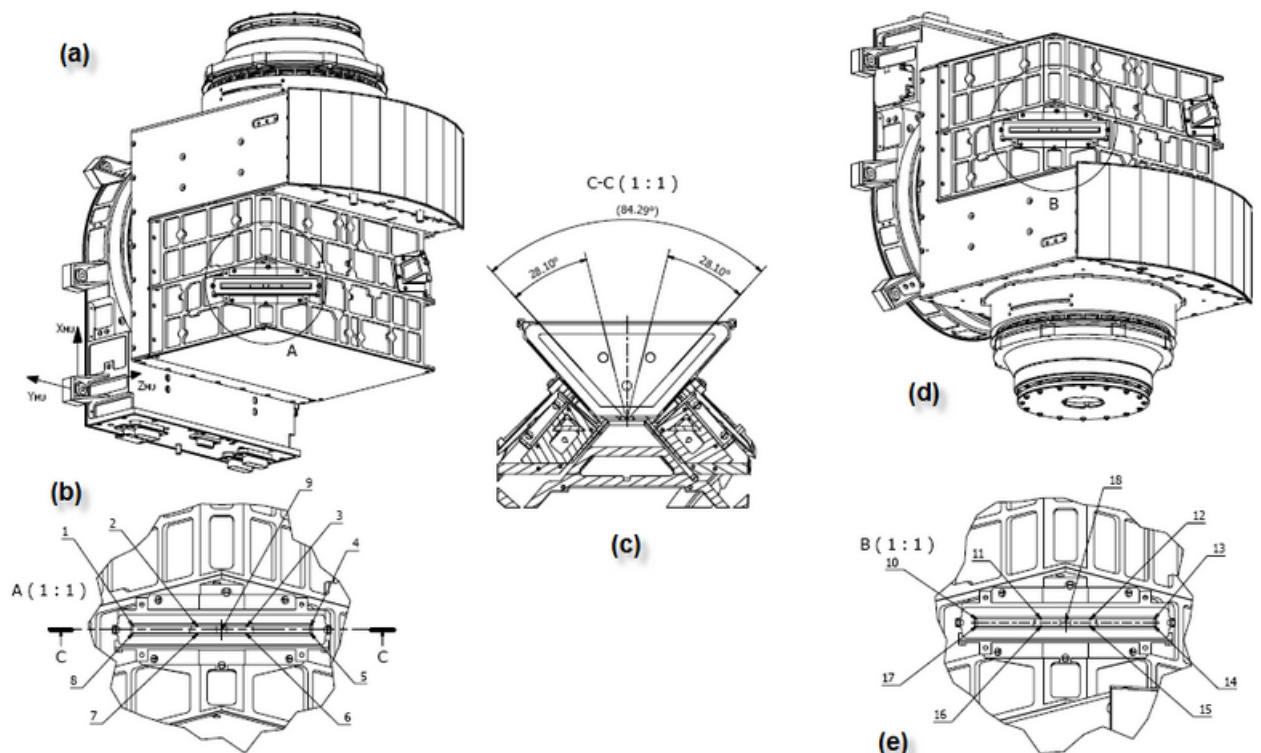

Figure 39. ASPERA-MU and NPD sensor [Courtesy Magnus Oja].

Table B– Geometry of NPD1 and NPD2 outer and inner apertures

NPD2	X	Y	Z
1	54.696	15.180	189.444
2	54.696	-4.138	208.762
3	54.696	-18.888	223.512
4	54.696	-38.206	242.830
5	51.798	-38.755	242.281
6	51.798	-19.437	222.963
7	51.798	-4.687	208.213
8	51.798	14.631	188.895
9	63.630	-39.874	187.774

NPD1	X	Y	Z
10	97.304	-233.180	189.444
11	97.304	-213.862	208.762
12	97.304	-199.112	223.512
13	97.304	-179.794	242.830
14	100.202	-179.245	242.281
15	100.202	-198.563	222.963
16	100.202	-213.313	208.213
17	100.202	-232.631	188.895
18	88.370	-178.126	187.774

Table (B) shows the exact geometry of the NPD1 and NPD2 outer and inner apertures relative to the ASPERA Unit Frame, from the ASPERA technical design files.

Appendix-B

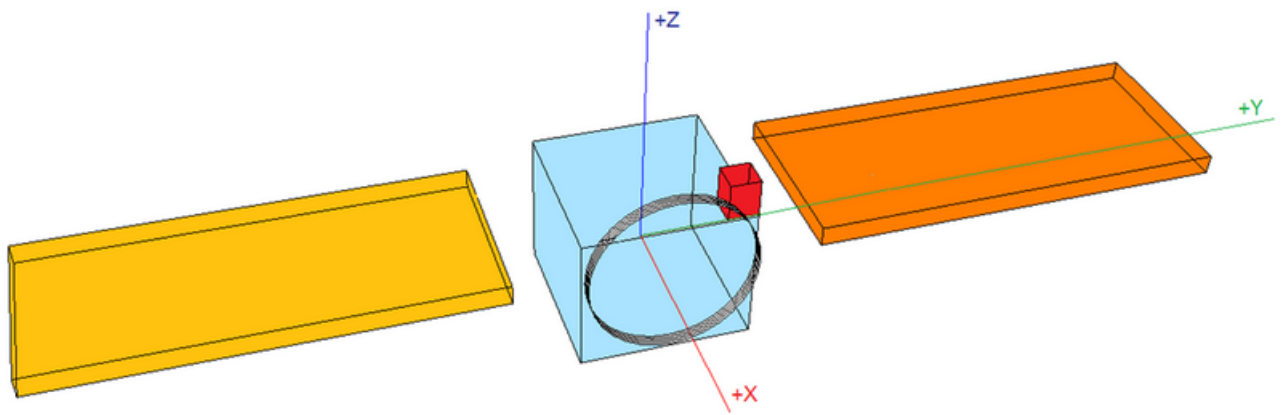

Figure 40. Mars Express

Appendix-C

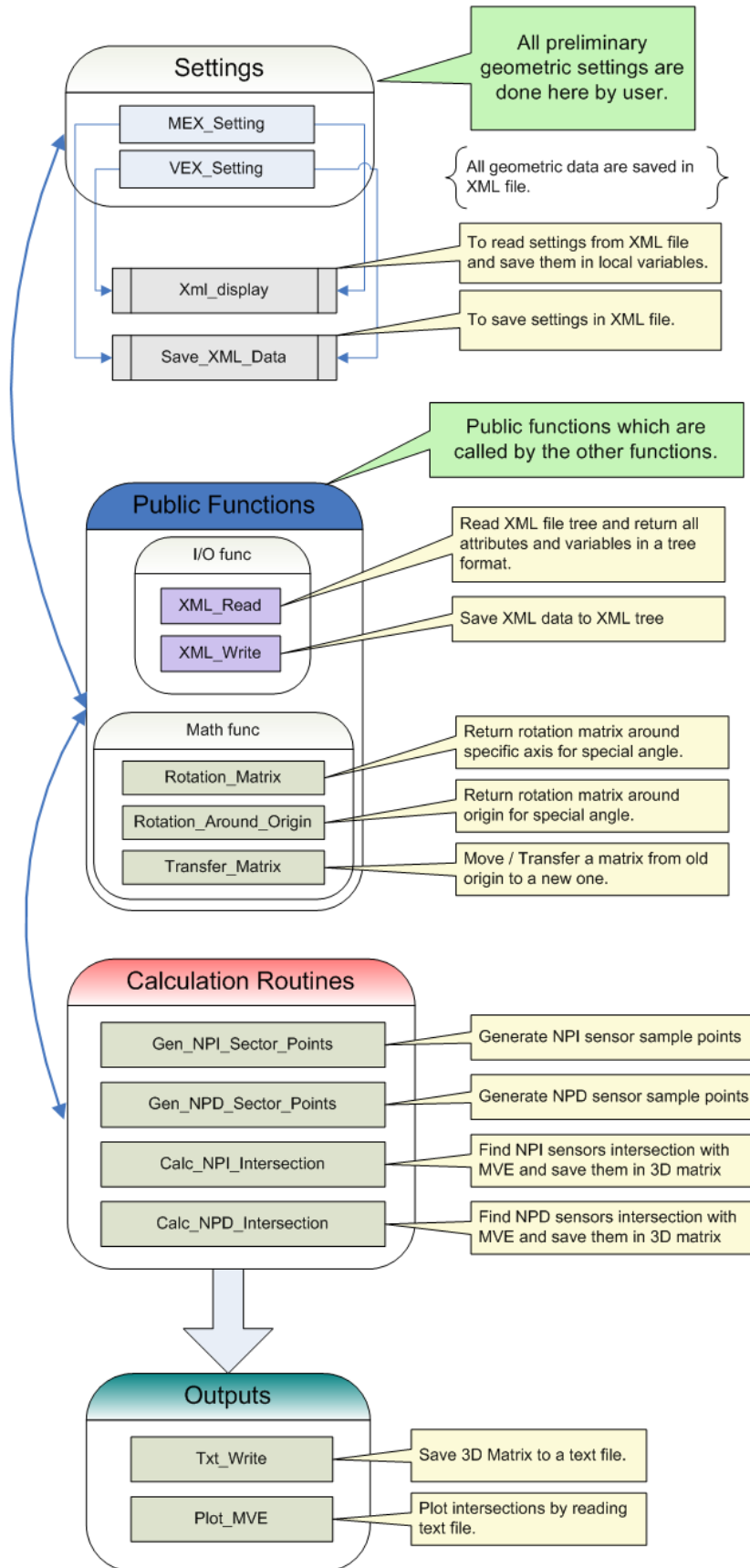

Figure 41. Functions block diagram

Appendix-D

Software GUI

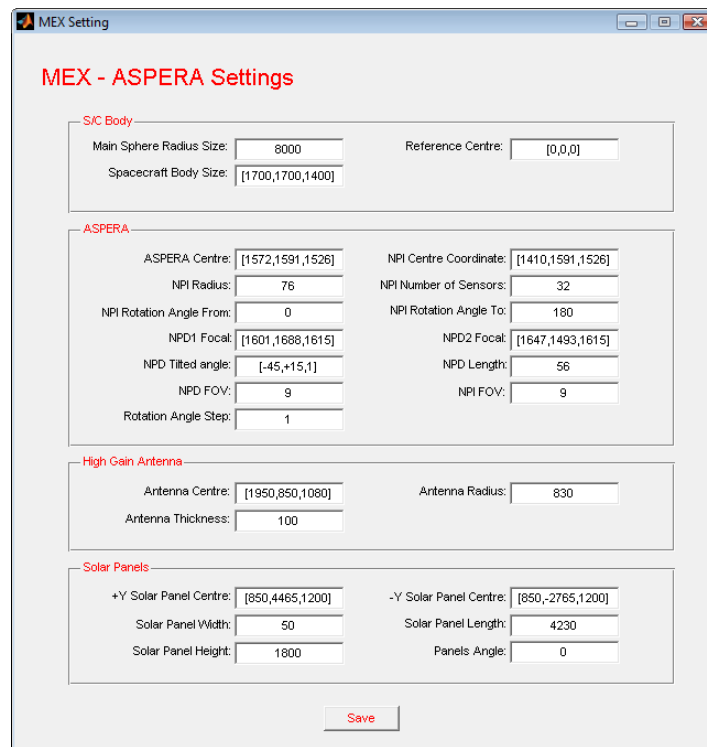

Figure 42. Mars Express geometric setting GUI

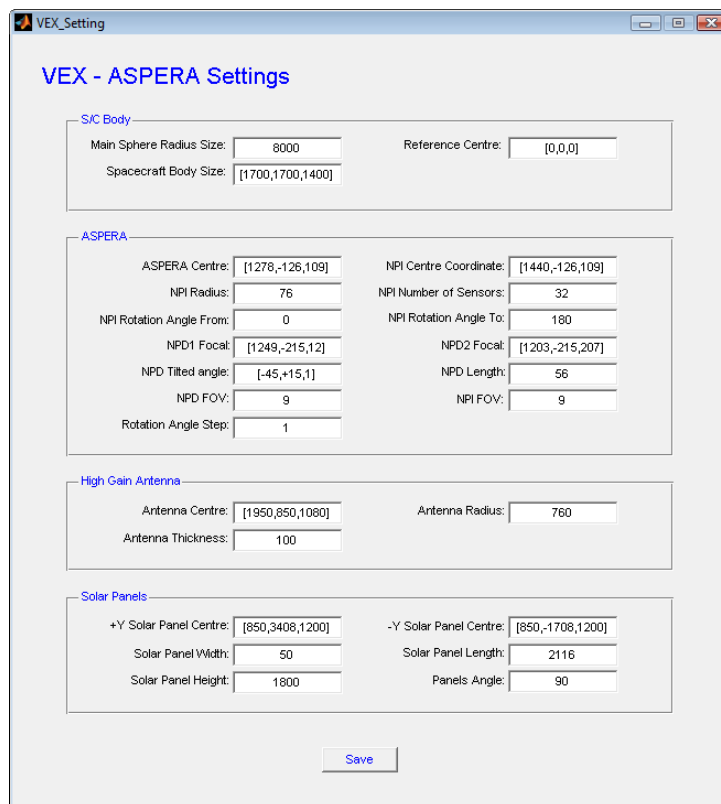

Figure 43. Venus Express geometric setting GUI

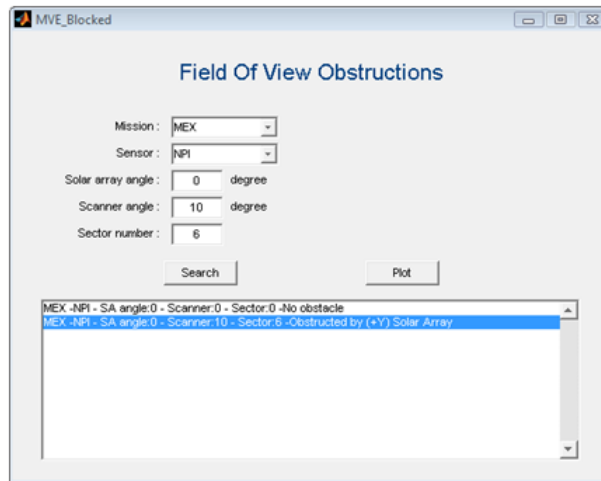

Figure 44. Search GUI

The user can choose the mission, sensor and solar array angle and find the obstructed sectors for different ASPERA-MU scanner angles.

Another simple function can be used to search the blocked sectors. This function gets inputs such as mission name, sensor name, solar array angle, ASPERA-MU scanner angle and sector number and returns an integer value that shows the obstruction part. This function and its instruction is shown below:

```
#####
% Function name: Blocked
%
% Created on: Jan 2009
% Updated on: Jan 2009
%
% *****
% Parameters:
% Mission:      Mission name. It accepts string values. set it to 'MEX'
%               for Mars Express or 'VEX' for Venus Express.
% Sensor:       Sensor name. It accepts string values. set it to 'NPI', 'NPD1' or 'NPD2'.
% SA_Angle:     Solar Array Angle. It accepts real values, between -90 to +90.
% Scanner_Angle: Scanner angle. It accepts real values, between 0 to +180.
% Sector_Number: Number of the sensor's sector. It accepts integer values, between 0 to 31
%               for NPI and 0 to 2 for NPD.
%
% *****
% How to call it:
% EXAMPLE: blocked ('MEX' , 'NPD1' , 45 , 60 , 1 )
% *** Attention: When you run this function, it looks for the file which
% contains the requested data. Therefore the file with those data should be
% existed. For example, in the example above, text file with NPD1 data
% for SA=60 deg for Mars Express is needed, which means that
% "MEX_NPD1_60.txt" should be existed in the folder that you run your query.
%
% *****
% Return value:
% -1: ERROR. Can not read the data or file does not exist.
% 0: if sector is not blocked.
% 1: if sector is blocked by S/C body.
% 2: if sector is blocked by H.G. Antenna.
% 3: if sector is blocked by (+Y) solar array.
% 4: if sector is blocked by (-Y) solar array.
%
% *****
% Description:
% Searching for NPI and NPD obstruction field of view.
%
```

```

%%%%%%%%%%%%%%%%%%%%%%%%%%%%%%%%%%%%%%%%%%%%%%%%%%%%%%%%%%%%%%%%%%%%%%%%%%
function Result=Blocked(Mission, Sensor, SA_Angle, Scanner_Angle, Sector_Number)
    Result = -1;
    % Global variable. Files data is stored in this matrix
    global DataMatrix;
    % get the file name
    txtFileName = getFileName(Mission, Sensor, round(SA_Angle), 1);
    % if user's query need to search the same file that searched before, it
    % doesn't read the file again. therefore, if the file is not the same
    % as before, it reads the data from the new file.
    if(SameFile(txtFileName) == 0)
        % Read the file and store in a matrix
        DataMatrix = [];
        % Fill the matrix.
        DataMatrix = ReadFile(txtFileName);
    end
    % data exist in the matrix
    if(length(DataMatrix)>0)
        % search for the requested scanner angle and sector number.
        Result = DataMatrix(round(Scanner_Angle)+1 , round(Sector_Number)+2);
    else
        display('Error ** No data to read. ');
    end
    return;
    %#####
    % if user's query need to search the same file that searched before, it
    % doesn't read the file again. therefore, if the file is not the same as
    % before, it reads the data from the new file.
    % This function is just responsible to find out the file name is the same
    % as before or not.
    % If it's the same, it returns 1, otherwise 0.
    function Result = SameFile(txtFileName)
        % storing the last file details.
        global Old_txtFileName;

        if(length(Old_txtFileName)==0)
            Old_txtFileName = txtFileName;
            Result = 0;
        else
            % if the file parameters are the same as before.
            if( strcmp(Old_txtFileName, txtFileName)==1 )
                Result = 1;
            % otherwise.
            else
                Old_txtFileName = txtFileName;
                Result = 0;
            end
        end
    end
    return;
    %#####
    % finding the name of the text file which the query should be run for.
    function txtFileName = getFileName (Mission, Sensor, SA_Angle, withFileFormat)
        txtText = Mission;
        % Add the selected text to command string
        txtFileName = txtText;
        % Get the selected values from Sensor.
        txtText = Sensor;
        if(withFileFormat == 1)
            % Add the selected text to command string
            txtFileName = strcat(txtFileName, '_', txtText, '_');
        else
            txtFileName = strcat(txtFileName, '_', txtText);
        end
        % Add the selected text to command string
        if(withFileFormat == 1)
            txtFileName = strcat(txtFileName , num2str(SA_Angle) , '.txt');
        end
    end
    return;
    %#####
    % Reading file data.
    % It returns a matrix which contains the file data.
    function Matrix = ReadFile(txtFileName)
    try,

```

```

Matrix = [];
% open the file.
fid = fopen(txtFileName);
if(fid < 0)
    display( '** ERROR ** Text file does not exist. ');
else
    C = textscan(fid,'%s', 'delimiter', '\n', 'whitespace', '');
    fclose(fid);
    % Read line.
    lines = C{1};
    Matrix=[];
    all_row=1;
    matrix_row=1;
    try,
        while(lines{all_row, :})
            if(strfind(lines{all_row, :}, '/*'))
                %disp('don't do anything')
            else
                % fill matrix.
                A = lines{all_row, :};
                Matrix(matrix_row,:)=strread(A , '%d');
                matrix_row = matrix_row+1;
            end
            all_row=all_row+1;
        end
    catch,
        %disp('don't do anything')
    end
end
catch,
end
return;
#####
% END
#####

```

References:

1. The Analyzer of Space Plasmas and Energetic Atoms (ASPERA-3) for the Mars Express Mission, S. Barabash, R. Lundin, H. Andersson, K. Brinkfeld, A. Grigoriev, H. Gunell, M. Holmström, et al., *Space Science Reviews*, 126(1–4):113–164, 2006.
2. The Analyzer of Space Plasmas and Energetic Atoms (ASPERA-4) for the Venus Express Mission, S. Barabash, J.-A. Sauvaud, H. Gunell, H. Andersson, A. Grigoriev, K. Brinkfeldt, M. Holmström, et al., *Planetary and Space Science*, 55(12):1772–1792, 2007.
3. South West Research Institute; ASPERA
http://www.aspera3.org/main/asp_h.htm
<http://www.aspera-3.org/ids/>
4. Max Planck Institute for Solar System Research
<http://www.mps.mpg.de/en/projekte/mars-express/aspera3/>
5. Mars Express Spacecraft and Beagle-2 Lander Frames Kernel.
ftp://gorilla.estec.esa.int/pub/projects/mex/data/spice/kernels/fk/MEX_V08.TF
6. Venus Express Spacecraft Frames Kernel.
ftp://gorilla.estec.esa.int/pub/projects/vex/data/spice/kernels/fk/VEX_V06.TF
7. ASPERA-3 sensor numbering. Stas Barabash, 2003.
8. ASPERA-4 frame definitions and sensors attitudes. Pene Nicolas, 2005.
9. ESA science and technology - Instrument design.
<http://sci.esa.int/science-e/www/object/index.cfm?fobjectid=34826>



Institutet för rymdfysik

Swedish Institute of Space Physics

Swedish Institute of Space Physics
Box 812, SE- 981 28 Kiruna, SWEDEN
tel. +46-980-790 00, fax +46-980-790 50, e-post: irf@irf.se

www.irf.se